

High Temperature Deep Cycle GEL Battery

HTGEL12-55

The HTGEL deep cycle gel battery adopts the advanced developed nano gel electrolyte with super-C additive plus heavy duty plates design inside. It has a longer service life even deep cycle discharge use and can provide optimum and reliable service under extreme condition such as high temperature and frequent power failure, thus it is highly suited for tropical area in outdoor applications such as Telecom BTS stations and Off-grid PV system.

| | | | |
|-----------------------|-------------------------|--------------------------|----------------------|
| 12V Voltage | 55Ah Capacity | Gel Technology | Deep Cycle |
|-----------------------|-------------------------|--------------------------|----------------------|



COMPLIED STANDARDS

IEC 60896-21/22 JIS C8704
 IEC61427 BS6290 part4
 GB/T 19638 CE/ISO

GENERAL FEATURES

- Able to operate at 40-60°C
- Integrated design to ensure the best uniformity and reliability
- Longer life and higher stability under high temp. environment (no air-con needed)
- Super-C additives: Deep discharge recovery capability, 1600cycles @50%DOD

APPLICATIONS

- BTS Stations
- Solar & Wind energy system
- UPS system
- Telecom systems
- Wheel chair, Golf cart

DIMENSIONS & WEIGHT

| | |
|-------------------|---------|
| Length (mm) | 229±1 |
| Width (mm) | 138±1 |
| Height (mm) | 208±1 |
| Total Height (mm) | 212±1 |
| Weight (kg) | 16.2±3% |

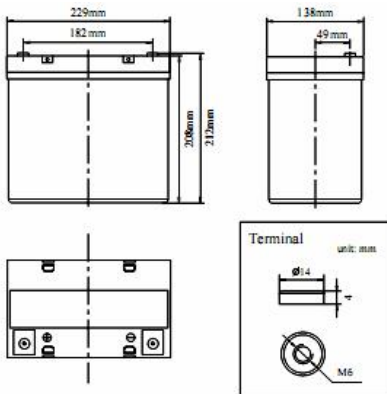

TECHNICAL SPECIFICATIONS

| | | |
|---|---------------------------|--|
| Nominal Voltage | | 12V (6 cells per unit) |
| Design Floating Life @25°C | | 20Years |
| Nominal Capacity @25°C (20 hour rate@2.75A,10.8V) | | 55Ah |
| Capacity @25°C | 10hour rate (50 A,10.8V) | 50Ah |
| | 5 hour rate (8.8A,10.5V) | 44Ah |
| | 1 hour rate (33.6A,9.6V) | 33.6Ah |
| Internal Resistance | Full Charged Battery@25°C | ≤10mΩ |
| Ambient Temperature | Discharge | -25°C~60°C |
| | Charge | -25°C~60°C |
| | Storage | -25°C~60°C |
| Max.Discharge Current@25°C | | 330A(5s) |
| Capacity affected by Temperature (10 hour rate) | 40°C | 108% |
| | 25°C | 100% |
| | 0°C | 90% |
| | -15°C | 70% |
| Self-Discharge@25°C per Month | | 3% |
| Charge (Constant Voltage) @25°C | Standby Use | Initial Charging Current Less than 12.5A Voltage 13.6-13.8V |
| | Cycle Use | Initial Charging Current Less than 12.5A Voltage 14.4-14.9V |

BATTERY DISCHARGE TABLE

Discharge Constant Current per Cell (Amperes at 25°C)

| F.V/Time | 15min | 30min | 45min | 1h | 2h | 3h | 5h | 8h | 10h | 20h | 100h |
|----------|-------|-------|-------|------|------|------|-----|-----|-----|------|------|
| 1.60V | 88.9 | 54.1 | 36.3 | 33.6 | 19.4 | 13.6 | 9.3 | 6.1 | 5.4 | 2.97 | 0.66 |
| 1.65V | 87.3 | 53.2 | 35.6 | 33.0 | 19.0 | 13.4 | 9.1 | 6.0 | 5.3 | 2.92 | 0.65 |
| 1.70V | 85.7 | 52.2 | 35.0 | 32.4 | 18.7 | 13.1 | 8.9 | 5.9 | 5.2 | 2.86 | 0.63 |
| 1.75V | 84.1 | 51.2 | 34.3 | 31.7 | 18.3 | 12.9 | 8.8 | 5.8 | 5.1 | 2.81 | 0.62 |
| 1.80V | 80.9 | 49.2 | 33.0 | 30.5 | 17.6 | 12.4 | 8.4 | 5.6 | 5.0 | 2.75 | 0.61 |

Discharge Constant Power per Cell (Watts at 25°C)

| F.V/Time | 15min | 30min | 45min | 1h | 2h | 3h | 5h | 8h | 10h | 20h | 100h |
|----------|-------|-------|-------|------|------|------|------|------|------|-----|------|
| 1.60V | 171.2 | 104.2 | 69.9 | 64.6 | 37.3 | 26.2 | 17.8 | 11.8 | 10.5 | 5.7 | 1.27 |
| 1.65V | 168.1 | 102.3 | 68.6 | 63.5 | 36.6 | 25.7 | 17.5 | 11.5 | 10.3 | 5.6 | 1.25 |
| 1.70V | 165.0 | 100.4 | 67.3 | 62.3 | 36.0 | 25.3 | 17.2 | 11.3 | 10.1 | 5.5 | 1.22 |
| 1.75V | 161.9 | 98.5 | 66.1 | 61.1 | 35.3 | 24.8 | 16.8 | 11.1 | 9.9 | 5.4 | 1.20 |
| 1.80V | 155.6 | 94.8 | 63.5 | 58.8 | 33.9 | 23.8 | 16.2 | 10.7 | 9.5 | 5.3 | 1.18 |

Note The above data are average values, and can be obtained within 3 charge/discharge cycles. These are not minimum values. Cell and battery designs/specifications are subject to modification without notice. Contact **VITO** for the latest information.

PERFORMANCE CHARACTERISTICS

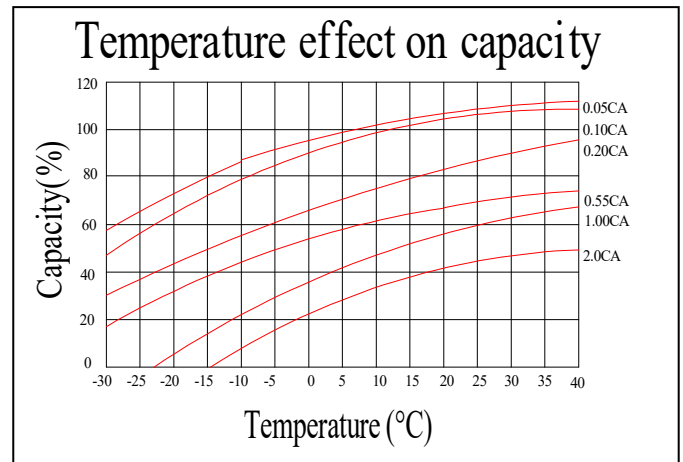
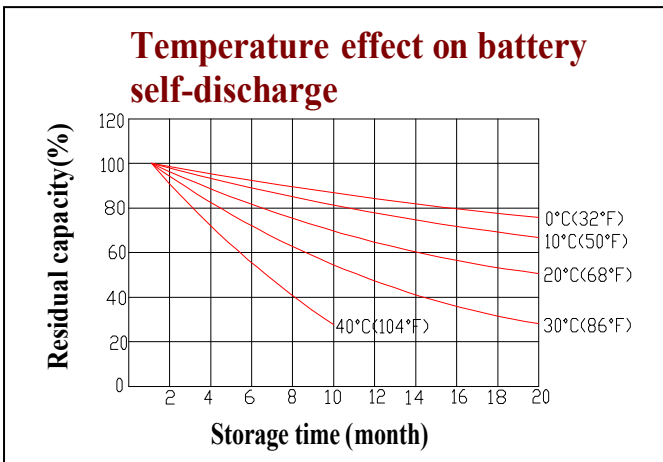
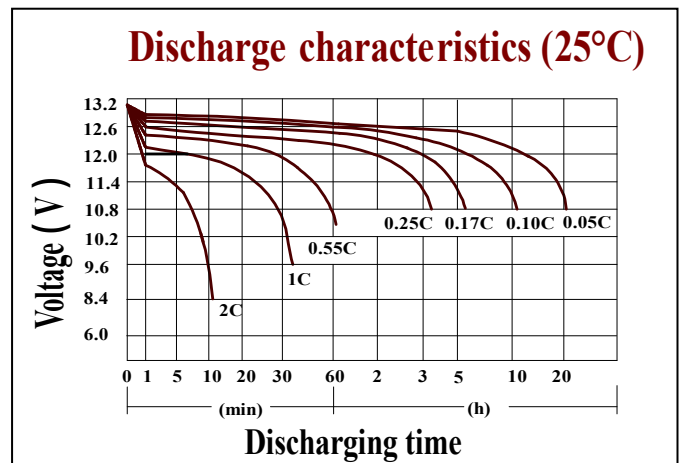
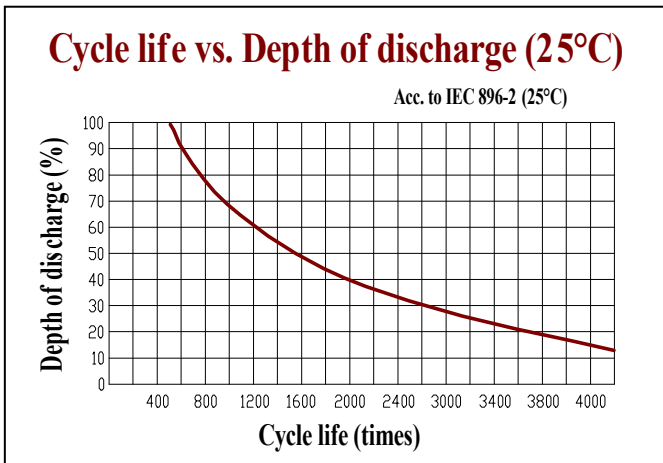
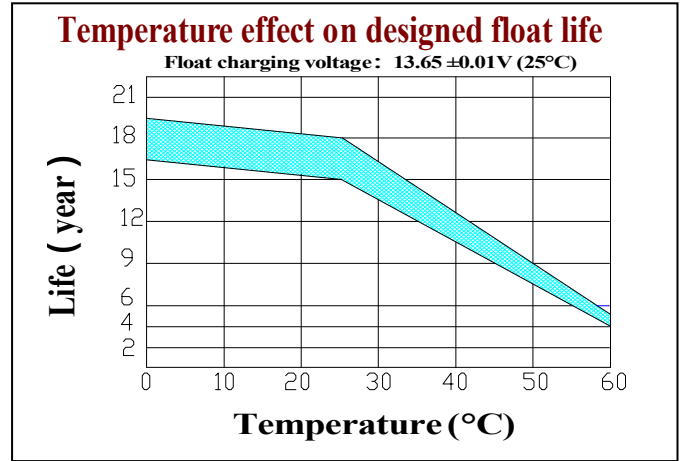
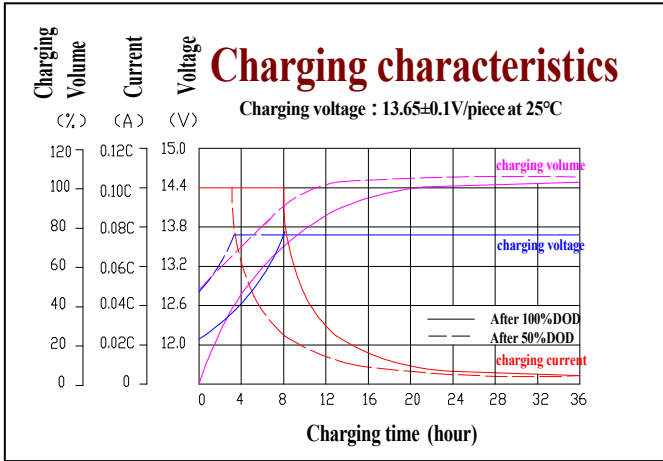

BATTERY CONSTRUCTION

| Component | Positive plate | Negative plate | Container & Cover | Safety valve | Terminal | Separator | Electrolyte | Pillar seal |
|-----------|--|---|---------------------|--------------------------------------|-------------------------|--|-------------|-----------------------------|
| Features | Thick high Sn low Ca grid with special paste | Balanced Pb-Ca grid for improved recombination efficiency | Fire resistance ABS | Flame Si-Rubber and aging resistance | Female Copper Insert M6 | Separator with organic fiber, very long service life | Silicon Gel | Two layers epoxy resin seal |

Vito Trade LTD.
Bulgaria, 6300 Haskovo city, №4 Plovdivsko schose street,
Phone +359877997479

www.vitolux.com