

High Temperature Deep Cycle GEL Battery

HTGEL12-70

12V Voltage	70Ah Capacity	Gel Technology	Deep Cycle
-----------------------	-------------------------	--------------------------	----------------------



The HTGEL deep cycle gel battery adopts the advanced developed nano gel electrolyte with super-C additive plus heavy duty plates design inside. It has a longer service life even deep cycle discharge use and can provide optimum and reliable service under extreme condition such as high temperature and frequent power failure, thus it is highly suited for tropical area in outdoor applications such as Telecom BTS stations and Off-grid PV system.

GENERAL FEATURES

- Able to operate at 40-60°C
- Integrated design to ensure the best uniformity and reliability
- Longer life and higher stability under high temp. environment (no air-con needed)
- Super-C additives: Deep discharge recovery capability, 1600cycles @50%DOD

APPLICATIONS

- BTS Stations
- Solar & Wind energy system
- UPS system
- Telecom systems
- Wheel chair, Golf cart

COMPLIED STANDARDS

IEC 60896-21/22 JIS C8704
IEC61427 BS6290 part4
GB/T 19638 CE/ISO

DIMENSIONS & WEIGHT

Length (mm)	350±1
Width (mm)	167±1
Height (mm)	178±1
Total Height (mm)	178±1
Weight (kg)	23.5±3%

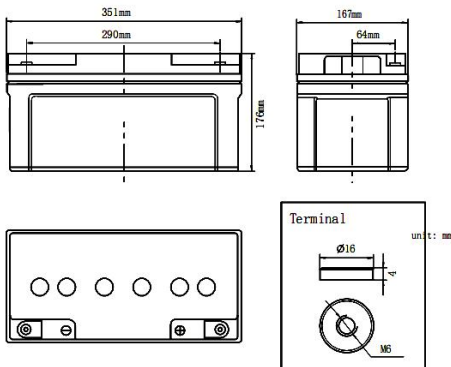

TECHNICAL SPECIFICATIONS

Nominal Voltage		12V (6 cells per unit)
Design Floating Life @25°C		20 Years
Nominal Capacity @25°C (20 hour rate@3.5A,10.8V)		70Ah
Capacity @25°C	10hour rate (6.5A,10.8V)	65Ah
	5 hour rate (11.1A,10.5V)	55.5Ah
	1 hour rate (42.7A,9.6V)	42.7Ah
Internal Resistance	Full Charged Battery@25°C	≤7.3 mΩ
Ambient Temperature	Discharge	-25°C~60°C
	Charge	-25°C~60°C
	Storage	-25°C~60°C
Max.Discharge Current@25°C		420A(5s)
Capacity affected by Temperature (10 hour rate)	40°C	108%
	25°C	100%
	0°C	90%
	-15°C	70%
Self-Discharge@25°C per Month		3%
Charge (Constant Voltage) @25°C	Standby Use	Initial Charging Current Less than 16.0A Voltage 13.6-13.8V
	Cycle Use	Initial Charging Current Less than 16.0A Voltage 14.4-14.9V

BATTERY DISCHARGE TABEL

Discharge Constant Current per Cell (Amperes at 25°C)

F.V/Time	15min	30min	45min	1h	2h	3h	5h	8h	10h	20h	100h
1.60V	113.2	68.9	46.2	42.7	24.7	17.3	11.8	7.8	6.9	3.78	0.84
1.65V	111.1	67.7	45.4	42.0	24.2	17.0	11.6	7.6	6.8	3.71	0.82
1.70V	109.1	66.4	44.5	41.2	23.8	16.7	11.4	7.5	6.7	3.64	0.81
1.75V	107.0	65.2	43.7	40.4	23.3	16.4	11.1	7.4	6.6	3.57	0.79
1.80V	102.9	62.7	42.0	38.9	22.4	15.8	10.7	7.1	6.5	3.50	0.78

Discharge Constant Power per Cell (Watts at 25°C)

F.V/Time	15min	30min	45min	1h	2h	3h	5h	8h	10h	20h	100h
1.60V	217.9	132.7	88.9	82.3	47.5	33.4	22.7	15.0	13.3	7.3	1.62
1.65V	213.9	130.2	87.3	80.8	46.6	32.7	22.3	14.7	13.1	7.1	1.59
1.70V	210.0	127.8	85.7	79.3	45.8	32.1	21.9	14.4	12.9	7.0	1.56
1.75V	206.0	125.4	84.1	77.8	44.9	31.5	21.4	14.2	12.6	6.9	1.53
1.80V	198.1	120.6	80.9	74.8	43.2	30.3	20.6	13.6	12.1	6.7	1.50

Note The above data are average values, and can be obtained within 3 charge/discharge cycles. These are not minimum values. Cell and battery designs/specifications are subject to modification without notice. Contact **VITO** for the latest information.

High Temperature Deep Cycle GEL Battery

HTGEL12-70

PERFORMANCE CHARACTERISTICS

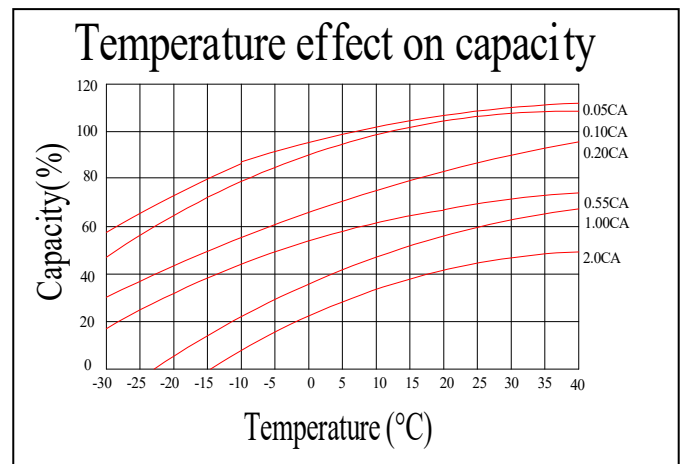
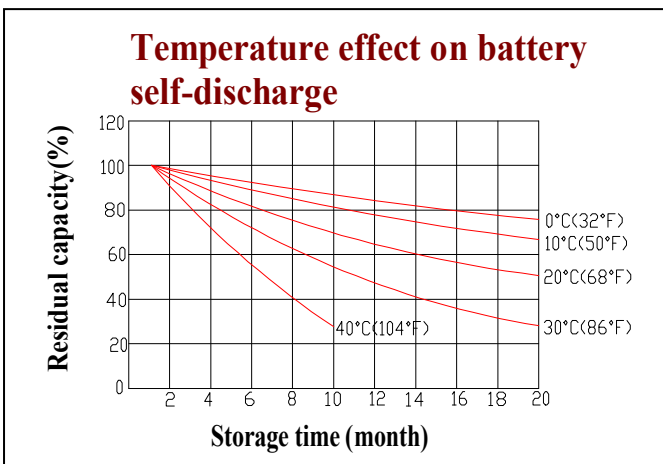
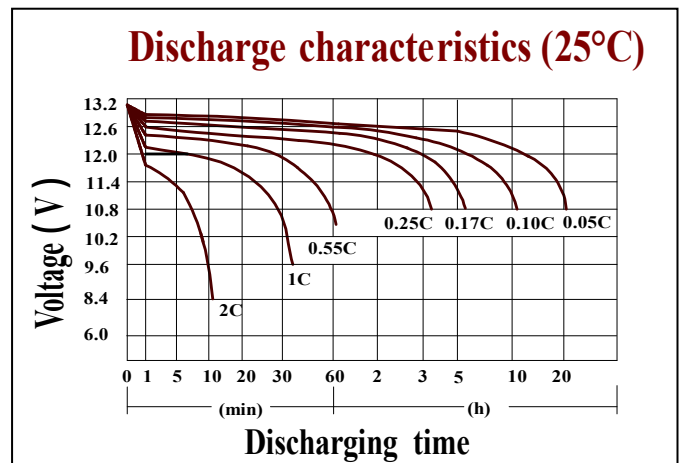
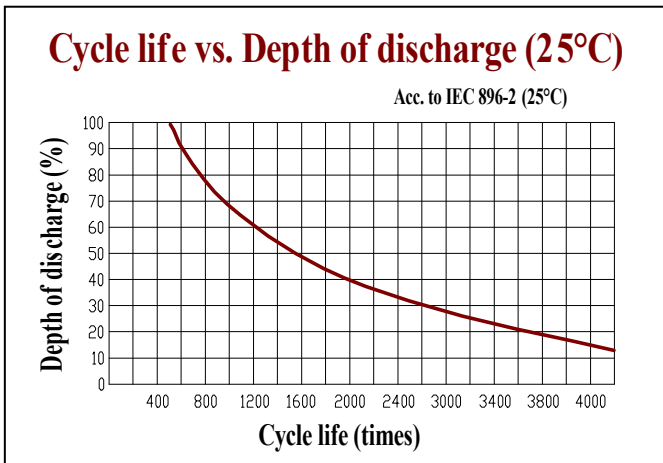
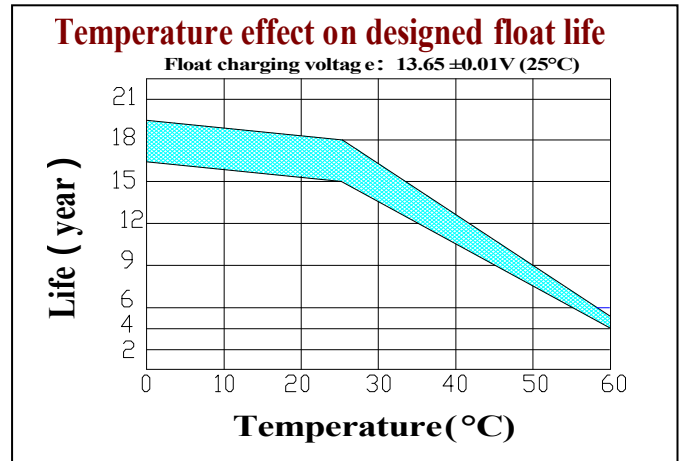
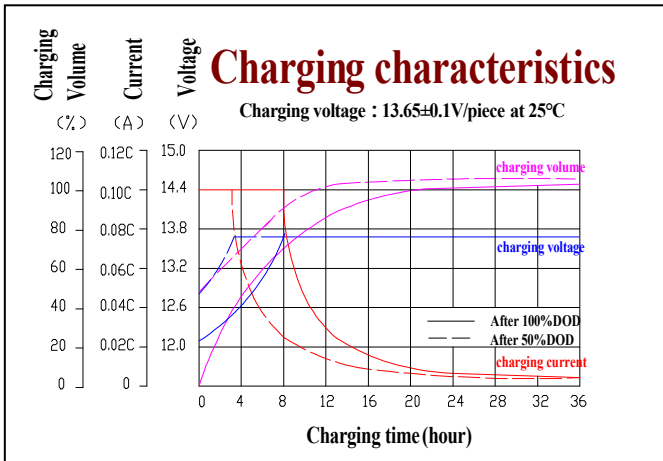

BATTERY CONSTRUCTION

Component	Positive plate	Negative plate	Container & Cover	Safety valve	Terminal	Separator	Electrolyte	Pillar seal
Features	Thick high Sn low Ca grid with special paste	Balanced Pb-Ca grid for improved recombination efficiency	Fire resistance ABS	Flame Si-Rubber and aging resistance	Female Copper Insert M6	Separator with organic fiber, very long service life	Silicon Gel	Two layers epoxy resin seal

Vito Trade LTD.

Bulgaria, 6300 Haskovo city, №4 Plovdivskoshoche street,
Phone +359877997479

www.vitolux.com