



USER'S MANUAL

Non-contact Triac Type
Automatic Voltage Regulator

RVXF Series
RVXS Series
(3,000VA - 20,000VA)

Before operating this product, please read these instructions carefully.

PLEASE READ AND SAVE THIS MANUAL

Congratulating you on selecting this Automatic Voltage Regulator(AVR)!

This manual is a guide to install and use the AVR properly, which includes important safety instructions.



This symbol gives information regarding the points important for user's health and safety, AVR operation and the safety of your data.



This symbol gives information, warnings, and other suggestions.

CONTENT

1. IMPORTANT SAFETY INSTRUCTIONS	P3
2. SPECIFICATIONS	
2.1. Main Specification	P4
2.2. Loading Capability Chart	P5
3. PACKING CONTENTS.....	P6
4. INTRODUCTION OF THE AVR	
4.1. Tower Type AVR	P6
4.2. Wall Mount Type AVR	P8
5. INSTALLATION OF THE AVR	
5.1. Connect the Electrical Appliances to the AVR.....	P13
5.2. Connect the AVR to Mains Power.....	P13
6. OPERATION OF THE AVR	
6.1. Delay Operation	P14
6.2. Switch on the AVR.....	P14
6.3. Over Voltage (High Voltage) Protection.....	P14
6.4. Under Voltage (Low Voltage) Protection.....	P15
6.5. Over Temperature Protection.....	P15
6.6. Short Circuit Protection	P15
6.7. Smart Overload Protection	P15
6.8. Out of Frequency Protection.....	P16
7. MAINTENANCE.....	P16
8. TROUBLE SHOOTING	P17

1. IMPORTANT SAFETY INSTRUCTIONS

- Make sure you carefully read all the instructions and warnings in this manual before installing and operating this AVR.
- To avoid any damage to the AVR, it is advised to transport the AVR in its own packing.
- Place all the cables in a proper place so that they are not be stepped on or get caught into people's feet.
- Don't drop any small materials (like clips, nails etc...) into the cabinet.
- In emergencies (such as damage to the cabinet, front panel, or power cord, splashing of liquid, dropping of any materials into the cabinet), switch off the AVR immediately, disconnect it from mains power, then inform the authorized dealer or service center.
- Don't connect any appliances to AVR, which exceeds its rated power capacity.



Earth cable should be chosen according to the current capacity!
All units' earth connections, which are connected to AVR, should be done with earth cable. Without earth connection or unproved earth connected units is dangerous for user's health, and has high risk of electronic circuit board faults. Using earth cable with improper diameter could be dangerous for user's health and safety of the unit.



The AVR can only be repaired by the authorized technical service personnel. Any attempt to open and to repair by the user on his own could prove to be dangerous.



Placing magnetic storage media on the top of the UPS may result in data corruption.



When the AVR input comes from a generator:

- Output power capacity must be higher than the AVR rating, otherwise the AVR and generator may not work properly;
- Output frequency of generator must be in range of 45 to 65Hz, and wave form must be sine wave, otherwise the AVR and generator may not work properly.

2. SPECIFICATIONS

2.1. Main Specification

Power Capacity	500VA - 20,000VA
Technology	Solid State Relay (Triac) Tap Change + Zero Cross Transfer Technology
Response Time	<50ms
Input & Output Voltage	Input 120-290V~, Output 230V~ ± 5%
Input Frequency	45-65Hz
Output Frequency	Same as input frequency
Protection	Under voltage, over voltage, overload, over temperature, out of frequency, short circuit, surge
Delay Time	6s / 180s selectable
Buzzer	Yes, will beep when AVR is overloaded
Protection Class	I
IP Class	IP20
Operating Temperature	-10°C - +40°C
Operating Humidity	<90%, non-condensing
Storage Temperature	-15°C - +45°C
Certification	CE (EMC + LVD)

* : Please refer to rating plate on the AVR for actual specification

2.2. Loading Capability Chart

At different input voltage, the loading capability of the AVR is different, please connect the appliances based on below loading chart, make sure the AVR is not overloaded.

Input Voltage (V)	Actual Loading Capability (% of Rated Power)
120	48%
130	53%
140	58%
150	65%
60	71%
170	73%
180	80%
190	86%
200	91%
210	99%
220	100%
230	100%
240	100%
250	100%
260	100%
270	100%
280	100%
290	100%

3. PACKING CONTENTS

Delivered pack includes:

AVR..... 1 piece
User's Manual..... 1 piece

4. INTRODUCTION OF THE AVR

4.1. Tower Type AVR: RVXF-128 Series (3,000VA-10,000VA)

• Front Panel of the AVR

Dual Digit Voltmeter and 3 LED Indicators

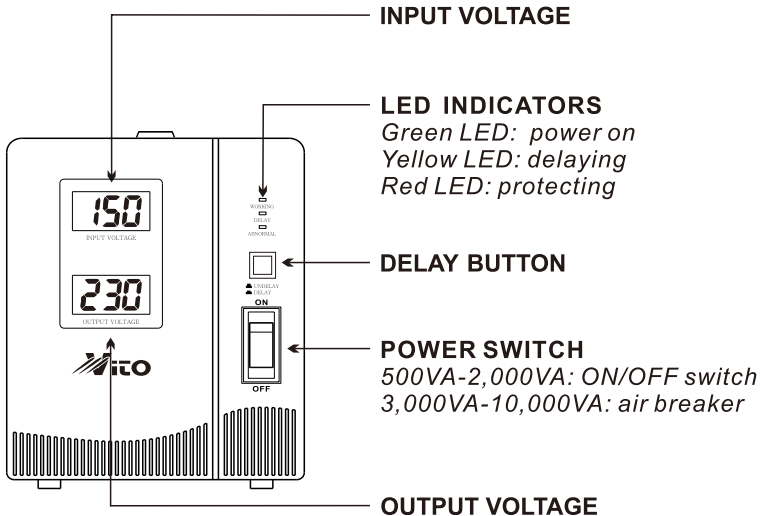

• Rear Panel of the AVR

Model # 3,000VA - 5,000VA

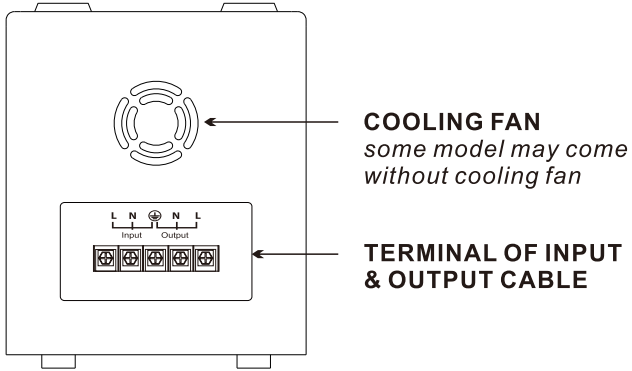

Model # 8,000VA - 10,000VA

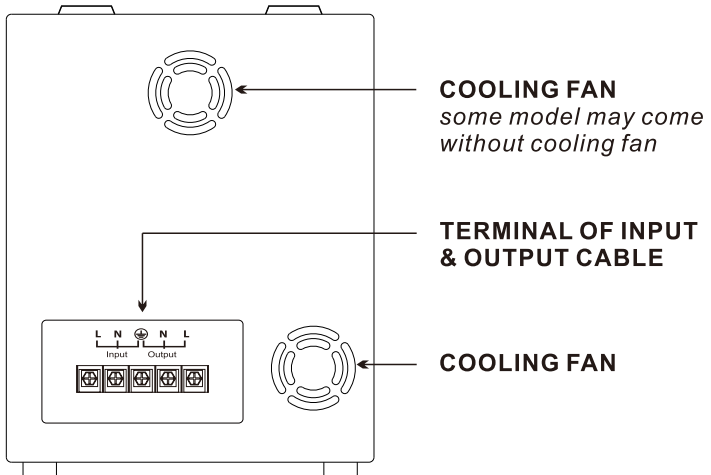

4.2. Wall Mount Type AVR: RVXS Series (10,000VA-20,000VA)

RVXS-124 Series

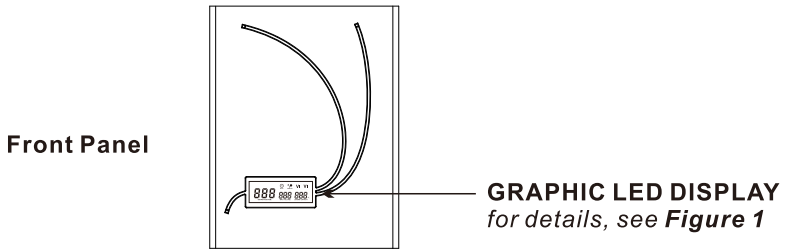
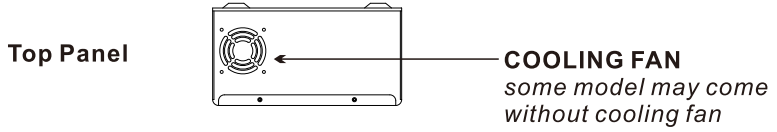

Left Side Panel

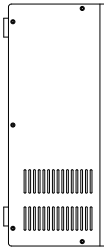

Right Side Panel

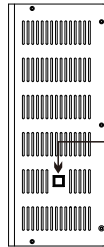

DELAY BUTTON

Bottom Panel

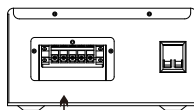

POWER SWITCH

**TERMINAL OF INPUT
& OUTPUT CABLE**

RVXS-125 Series

Top Panel

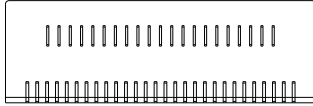

Front Panel

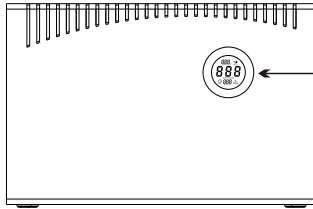

GRAPHIC LED DISPLAY
for details, see Figure 2

Left Side Panel

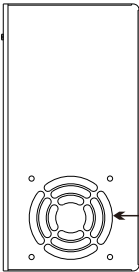

COOLING FAN
some model may come without cooling fan

Right Side Panel

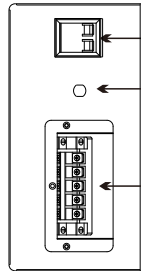

POWER SWITCH

DELAY BUTTON

TERMINAL OF INPUT & OUTPUT CABLE

Bottom Panel

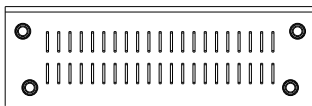

RVXS-126 & 127Series

Top Panel

Model # 10,000VA - 12,000VA

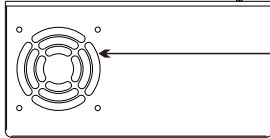

COOLING FAN
*some model may
come without
cooling fan*

Model # 15,000VA - 20,000VA

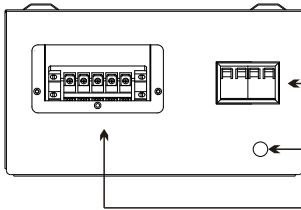

POWER SWITCH

DELAY BUTTON

**TERMINAL OF INPUT
& OUTPUT CABLE**

Front Panel

Model # RVXS-126 Series

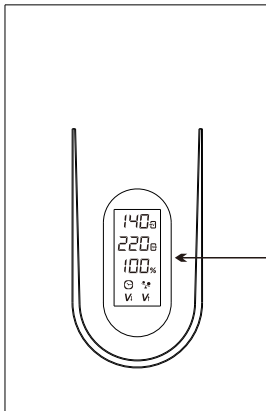

GRAPHIC LED DISPLAY
*for details, see **Figure 3***

Front Panel

Model # RVXS-127 Series

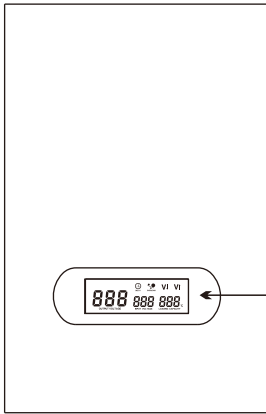

GRAPHIC LED DISPLAY
for details, see *Figure 2*

Bottom Panel

Model # 10,000VA - 12,000VA

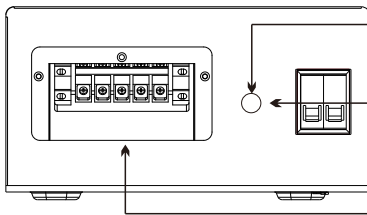

DELAY BUTTON

POWER SWITCH

**TERMINAL OF INPUT
& OUTPUT CABLE**

Model # 15,000VA - 20,000VA

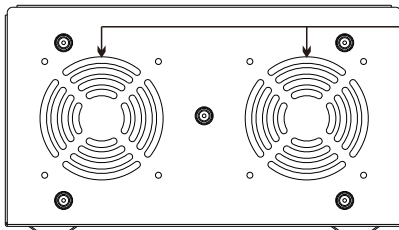

COOLING FAN

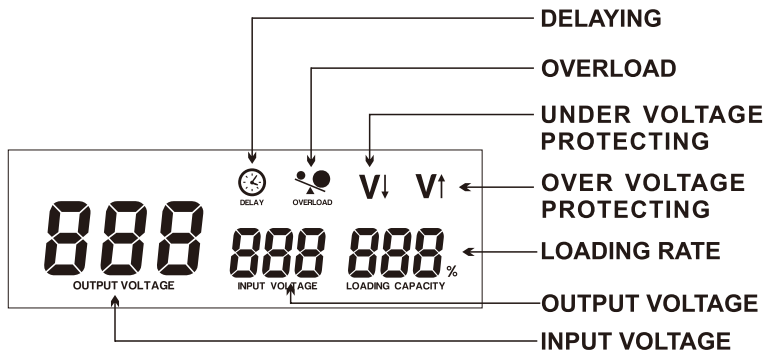

Figure 1

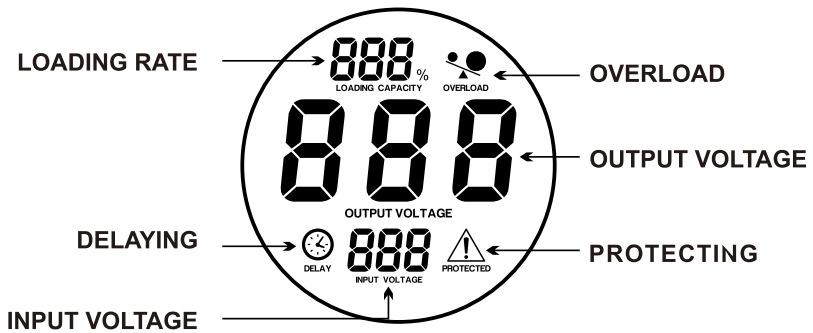

Figure 2

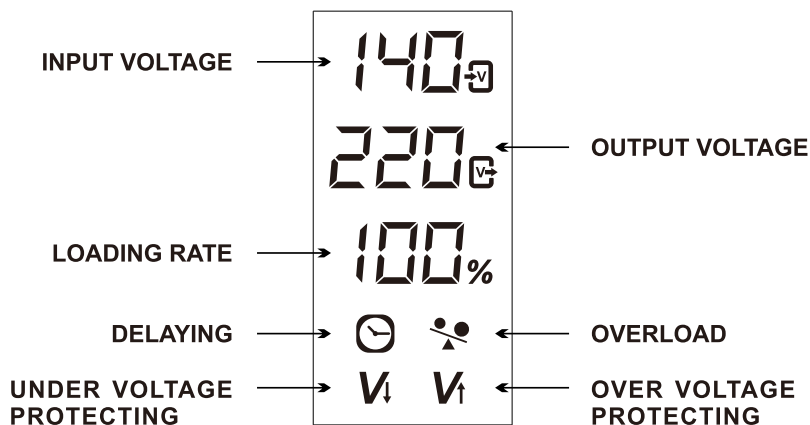

Figure 3

5. INSTALLATION OF THE AVR



Install the AVR in a cool, dry and clean place, away from windows, dust, moisture and cold to prevent fire or electrical shock, do not expose the AVR to rain or water.

- Install the AVR in a place where the children can't reach for.
- Do not install the AVR in or near water.
- Do not place AVR on an unstable cart, stand or table.
- Do not place AVR under direct sunlight or excessive humidity.
- Keep away from fire and heat sources.
- Keep away from corrosive gas or fluid.

5.1. Connect the Electrical Appliances to the AVR

- Make sure all appliances are turned "**OFF**", and put the **POWER SWITCH** of AVR to "**OFF**" position.
- For 500-2,000VA, plug the appliances into the **OUTPUT SOCKET** of the AVR
For 3,000-10,000VA, make wiring connection as shown in **Figure 2**.

5.2. Connect the AVR to Mains Power

- For 500-2,000VA, plug the **AC INPUT CABLE** into wall socket.
For 3,000-10,000VA, make wiring connection as shown in **Figure 2**.

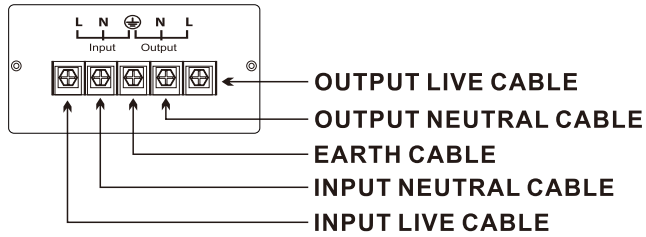

Figure 2

6. OPERATION OF THE AVR

6.1. Delay Operation

The “**DELAY**” means the output of the AVR will be delayed for a specific time, after switching on the AVR or the output is restored from a protecting status. It will prevent the appliances from being damaged due to frequent switching on and off .



Undelay



Delay

The default delay time is 6 seconds (UNDELAY) or 3 minutes (DELAY). Press down the **DELAY BUTTON** to select the “DELAY”, or press it up to select the “UNDELAY”.



For the appliances with motors and compressors, like **fans, refrigerators, cooler, freezers, air-conditioners, pumps, small motors**, please select  **Delay** .

6.2. Switch on the AVR

- Push the **POWER SWITCH** to “**ON**” position to switch on the AVR.
- Switch on the appliances one by one.
If more than one appliance is connected, please switch on from the big capacity at first, then the smaller one, and the smallest one at the last.

In Case of Power Failure:

- Switch off the AVR and all the appliances.
- Repeat above steps when power is restored.

6.3. Over Voltage (High Voltage) Protection

- In case that input voltage is over the normal range, the output will be cut off automatically and a letter “**H**” will be shown in the display.
- When input mains power returns to normal range, the AVR will restore the output automatically.

6.4. Under Voltage (Low Voltage) Protection

- In case that input voltage is below the normal range, the output will be cut off automatically and a letter “L” will be shown in the display..
- When input mains power returns to normal range, the AVR will restore the output automatically.

6.5.Over Temperature Protection

- In case that the temperature of Triacs is beyond the normal range, the output will be cut off automatically and letter “C” will be flashing in the display.

In case that the temperature of transformer windings is beyond the normal range, the output will be cut off automatically and letter “t” will be flashing in the display.

- When temperature of transformer windings or Triacs returns to normal range, the AVR will restore the output automatically.

6.6.Short Circuit Protection

- In case a short circuit happens to the AVR or appliances, the **AIR BREAKER** or **CIRCUIT BREAKER** will trip off to cut off the input power supply.
- Check if the appliances have been short circuited, if so, please remove them.



If the AVR is short circuited, do not use it! Please turn to the authorized dealer or service center.

6.7. Smart Overload Protection

- Once the it is overloaded, the AVR will give beeping and display warning to inform the user to reduce the connected appliances.

When load is >110%±8%: AVR gives beeping, output will be cut off within 30s if overload is not removed

When load is >120%±8%: AVR gives rapid beeping, output will be cut off within 5s if overload is not removed

- Once it's protected, the AVR will retry to restore output for 3 times, if overload is still not removed during this period, the AVR will stop retrying to restore output, at this time a letter “P” will be flashing in the display and AVR will give rapid beeping for once (last for 3s) every 2 minutes.

- When letter “P” is flashing, even if the overload is removed, the output won’t be restored. In this case, please conduct below steps:

- (a) Put the “**POWER SWITCH**” to “**OFF**” position to disconnect mains power
- (b) Switch off all the connected appliances, and remove the exceeding load
- (c) Switch on AVR and then switch on the appliance.

6.8. Out of Frequency Protection

- Once input frequency is out of range, the output will be cut off automatically and letter “**F**” will be flashing in the display.
- When input frequency returns to normal range, the AVR will restore the output automatically.

7. MAINTENANCE

This AVR is basically maintenance free! But regular maintenance can extend the life span of the AVR by the following steps:









Regular inspection

- Disconnect the AVR from the mains power completely.
- Use cotton cloth and detergent to clean the body and ventilation holes.
- Check all the terminals, replace the abnormal one with that of the same specification.

Extraordinary inspection

- When malfunction occurs, or the AVR is abnormal, please measure and check the parameters, refer to the authorized dealer if needed.
- In thunder and lightning or rainy season, Extraordinary Inspection should be executed to prevent malfunction.
- Maintenance should not be operated when AVR is working.

8. TROUBLE SHOOTING

Code	Code Status	AVR Status	What to do
 OUTPUT VOLTAGE	<i>Steady</i>	<i>Input under voltage protection</i>	<i>Wait till input voltage increases to normal range</i>
 OUTPUT VOLTAGE	<i>Steady</i>	<i>Input over voltage protection</i>	<i>Wait till input voltage decreases to normal range</i>
 OUTPUT VOLTAGE	<i>Flashing</i>	<i>Over temperature protection for Triac</i>	<i>Wait till the temperature of Triac decreases to normal range</i>
 OUTPUT VOLTAGE	<i>Flashing</i>	<i>Over temperature protection for transformer</i>	<i>Wait till the temperature of transformer decreases to normal range</i>
 OUTPUT VOLTAGE	<i>Steady</i>	<i>Output voltage is out of range while input voltage is within normal range</i>	<i>Contact the dealer</i>
 OUTPUT VOLTAGE	<i>Flashing</i>	<i>AVR is heavily overloaded like 4-5 times</i>	<i>Remove unnecessary appliances connected; if still not solved, contact the dealer</i>
 OUTPUT VOLTAGE	<i>Steady</i>	<i>Countdown time in minute for a retry to restart AVR once an overload happened</i>	<i>Wait till the countdown is finished</i>
 OUTPUT VOLTAGE	<i>Flashing</i>	<i>Overload protection</i>	<i>Remove unnecessary appliances</i>
 OUTPUT VOLTAGE	<i>Flashing</i>	<i>Protection of out of frequency</i>	<i>Wait till input frequency backs to normal range 45-65Hz</i>

The logo for Wilo, featuring a stylized 'W' with three curved lines to its left, followed by the lowercase letters 'ilo' and an uppercase 'O' in a bold, sans-serif font.

Wilo